

GAVETAS CERRADAS

MÓDULO EXTERNO

DIVISIONES AJUSTABLES

CAJA INTERNA

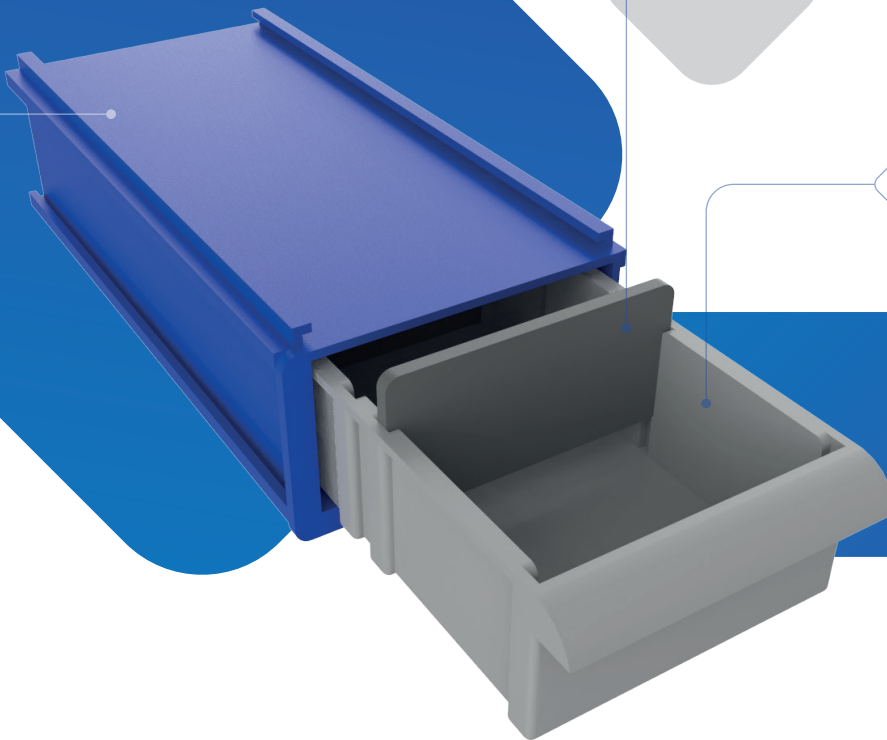

GC-02

CÓDIGO: PTOGA201002

DIMENSIONES GENERALES

Unidad: mm

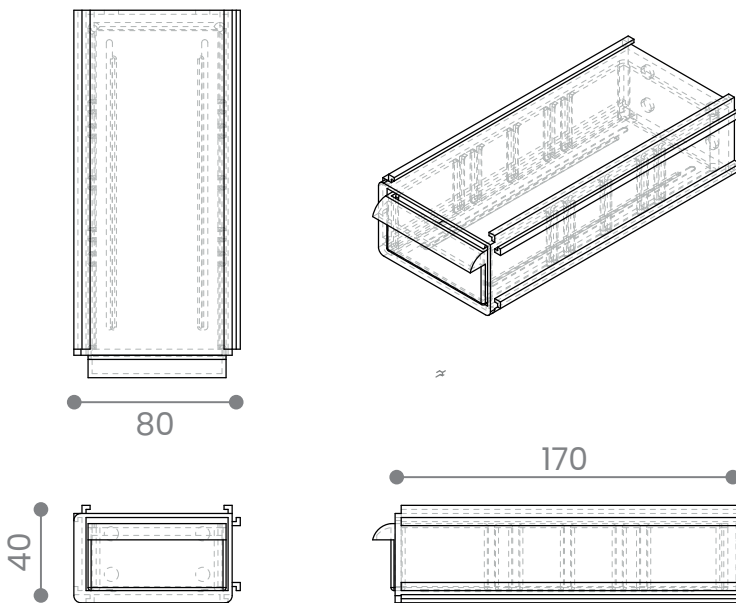

MATERIAL

MÓDULO EXTERNO
DIVISIONES
Poliestireno
de alto impacto



CAJA INTERNA
Polipropileno
copolímero de alto impacto



COLOR



PLASTEX

DISTRIBUIDOR EXCLUSIVO



MODUPLASTIC S.A.S
SISTEMAS DE ORGANIZACIÓN ALMACENAJE Y LOGÍSTICA

Ventas Región Sierra:
ventas@plastex.com.ec
Cel: +593 98 601 4170

Ventas Región Costa:
ventas4@plastex.com.ec
Cel: +593 99 357 8778

Ventas Planta Quito
Ventas2@plastex.com.ec
+593 2 306 8974 ext. 203

Marketing
marketing@plastex.com.ec

Dirección Comercial
comercial@plastex.com.ec



CAPACIDAD VOLUMÉTRICA

0.54 L



RESISTENCIA INTERNA

5 Kg



PESO

107 gr



SISTEMA MODULAR AUTÓNOMO



AGILIZA

Los procesos de picking



SE ADAPTA

A cualquier espacio



OPTIMIZA

Espacio



EXTENSA

Vida útil

GUÍAS DE ENSAMBLE

Horizontal
y Vertical

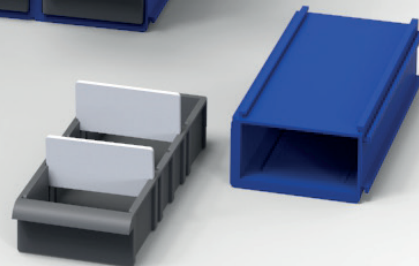
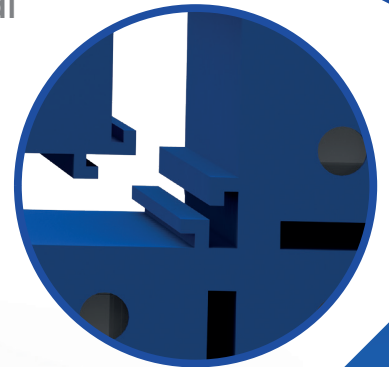

PLASTEX

DISTRIBUIDOR EXCLUSIVO



MODUPLASTIC S.A.S
SISTEMAS DE ORGANIZACIÓN ALMACENAJE Y LOGÍSTICA

Ventas Región Sierra:
ventas@plastex.com.ec
Cel: +593 98 601 4170

Ventas Región Costa:
ventas4@plastex.com.ec
Cel: +593 99 357 8778

Ventas Planta Quito
Ventas2@plastex.com.ec
+593 2 306 8974 ext. 203

Marketing
marketing@plastex.com.ec

Dirección Comercial
comercial@plastex.com.ec